



Low-Profile Transfer Conveyor

| | |
|---------------|---------------------------------------------------------------------------------|
| Capacity | Up to 7,500 BPH (Capacity depends on material, moisture, density, and angle) |
| Tubing | 10" Diameter Tubes |
| Belt | 15" 2-Ply Chevron |
| Belt Speed | Standard 300-550 FPM |
| Drive Options | Electric 5 HP, Gas 8 HP or Hydraulic Drive |
| Hopper | Collapsible Canvas Hopper |
| Construction | Carbon or Stainless Steel Available |



LOW-PROFILE TRANSFER CONVEYOR

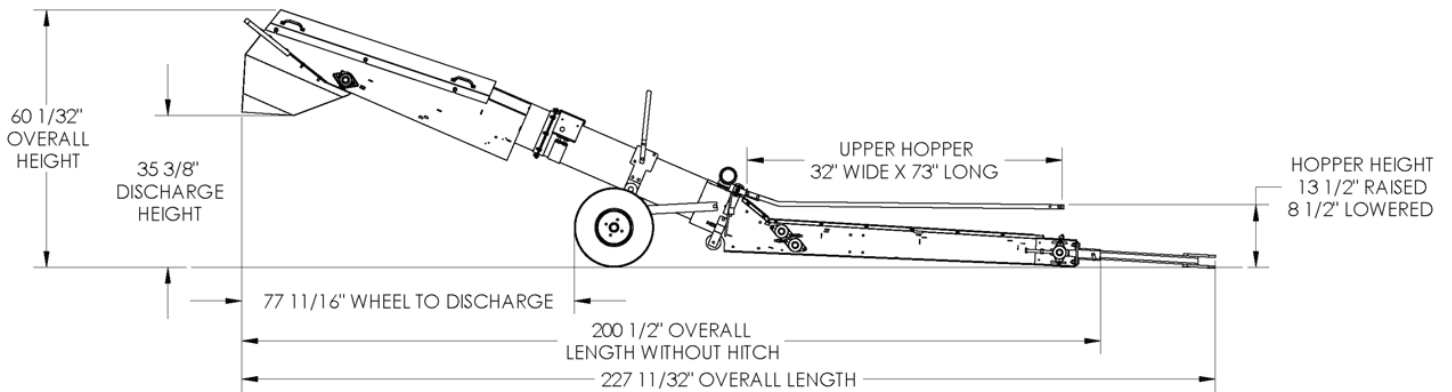

Specifications are subject to change without notice.

Uni Tube® is a brand of Universal Industries®



Unit application, location and specifications determine the type, quantity and/or placement of electrical, electrical safety or other safety controls required. Whether these controls are supplied by Universal Industries or another supplier, all OSHA safety and health standards, the National Electrical Code and local codes must be met and followed. Because we constantly strive to provide the finest material handling equipment, establishing industry standards, specifications must remain subject to change without notice.