



2200 Series Custom Pit Conveyor

Capacity	Up to 10,000 BPH (Capacity depends on material, moisture, density, and angle)
Tubing	14" Diameter Tubes
Belt	22" 2-Ply Chevron
Belt Speed	Standard 600 FPM
Drive	Electric
Hopper Length	Variable (1 ft. Increments)
Construction	Carbon Steel Available
Discharge Height	Minimum: 37" / Max: 84½" with 10' Tube Extension
Standard Accessories	Wind Guards
Optional Accessories	Bottom Covers



2200 SERIES PIT CONVEYOR

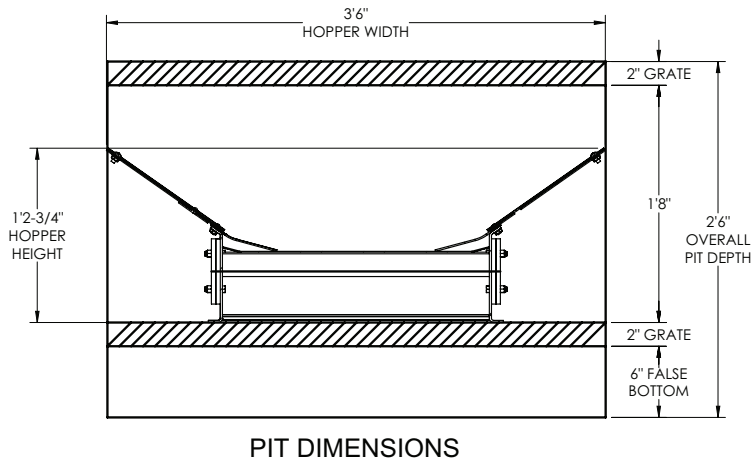
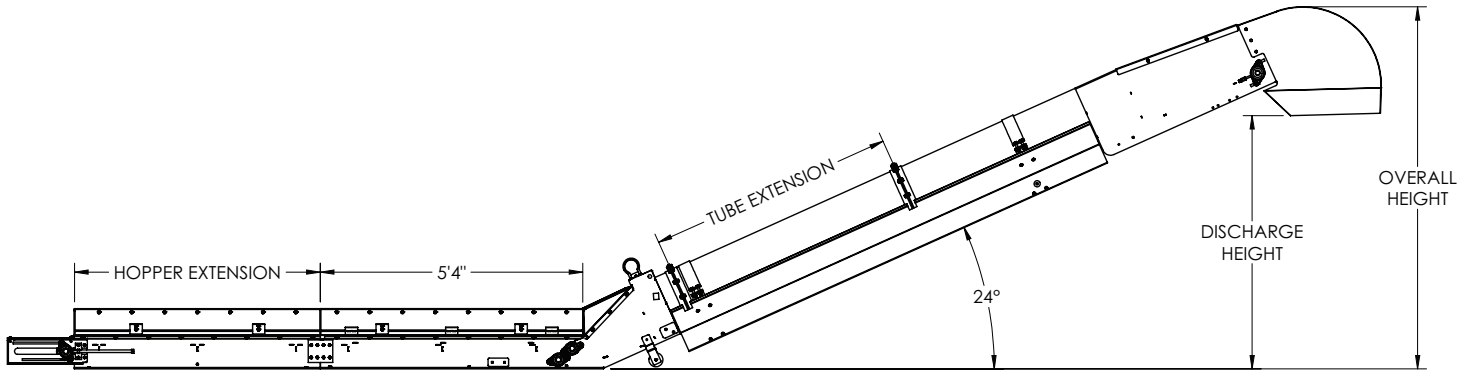

PIT DIMENSIONS

Specifications are subject to change without notice.

Uni Tube® is a brand of Universal Industries®



Unit application, location and specifications determine the type, quantity and/or placement of electrical, electrical safety or other safety controls required. Whether these controls are supplied by Universal Industries or another supplier, all OSHA safety and health standards, the National Electrical Code and local codes must be met and followed. Because we constantly strive to provide the finest material handling equipment, establishing industry standards, specifications must remain subject to change without notice.